

Date:	Project Name:
Type:	Part Number:



# HELIOS SERIES

## LED WRAP AROUND



### DESCRIPTION

The Helios series embraces a minimalist design while providing a wide array of features making this fixture adaptable to any indoor application. Utilize the colour and wattage selections built into the fixture to create the perfect look. Easy to install and built to last, this series is sure to impress.

#### FEATURES

- DLC Standard
- Optional integrated sensor available
- Dual Voltage 120-347V
- 0-10V Continuous Dimming
- Surface or Suspension Mounting options
- Easy and Safe Installation
- Frosted Polycarbonate Lens
- Rated Lifetime L70(hrs): >100,000
- Ambient Temperature: -22°F to 122°F (-30°C to 50°C)
- Suitable for Damp Locations
- Includes Coverplate and V-Hangers
- Sensor Available
- CRI > 80
- 5 year warranty

#### APPLICATIONS

-  Corridors
-  Education Facilities
-  Low Bay Application
-  Multi-res/Retirement



Date:	Project Name:
Type:	Part Number:

## SPECIFICATION

ORDER#	MODEL#	WATTS	VOLTAGE (V)	HOURS RATING	EFFICACY lm/W	CCT (K)	DLC STANDARD
R38001	RENO-HWR2-MW-DV-MCCT	12/15/18/22W	120-347V	100,000	130 lm/W	35/40/50K	✓
R38002	RENO-HWR4-MW-DV-MCCT	22/28/34/44W	120-347V	100,000	130 lm/W	35/40/50K	✓

## ACCESSORIES

ORDER#	MODEL#	DESCRIPTION
R83004	RENO-EM-C08	EMERGENCY LED DRIVER

## SENSOR OPTIONS

ORDER#	MODEL#	DESCRIPTION
R74002	RENO-SENSOR-PIR-H-EX	For external mounting when installed above 13FT

## REMOTE OPTIONS

ORDER#	MODEL#	DESCRIPTION
R73002	RENO-REMOTE-H	Remote Control

Date:	Project Name:
Type:	Part Number:

## DIMENSIONS

**2FT.**

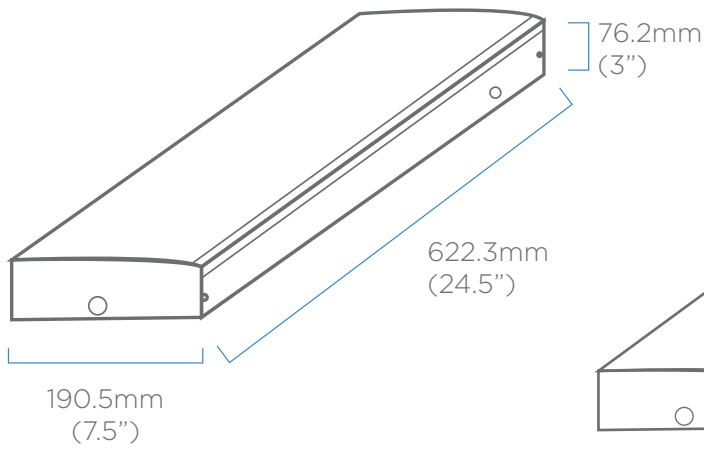

**4FT.**

